

NOTES: UNLESS OTHERWISE SPECIFIED

- 1. ALL SURFACES AND LOFTS ARE DERIVED FROM SOLID MODEL. THE SOLID MODEL IS THE MASTER AND CONTROLS ALL DIMENSIONS, UNLESS OTHERWISE SPECIFIED. ENGINEERING WILL SUPPLY ALL LOFTED DATA UPON REQUEST.
- 2. All surfaces to be "as machined"
- 3. Noted surfaces shall be free from scratches, marks and abrasions of any kind. (see isometric views)

REVISIONS			
REV	DESCRIPTION	DATE	APPVD
A	additional dimensions	03/24/15	JAL

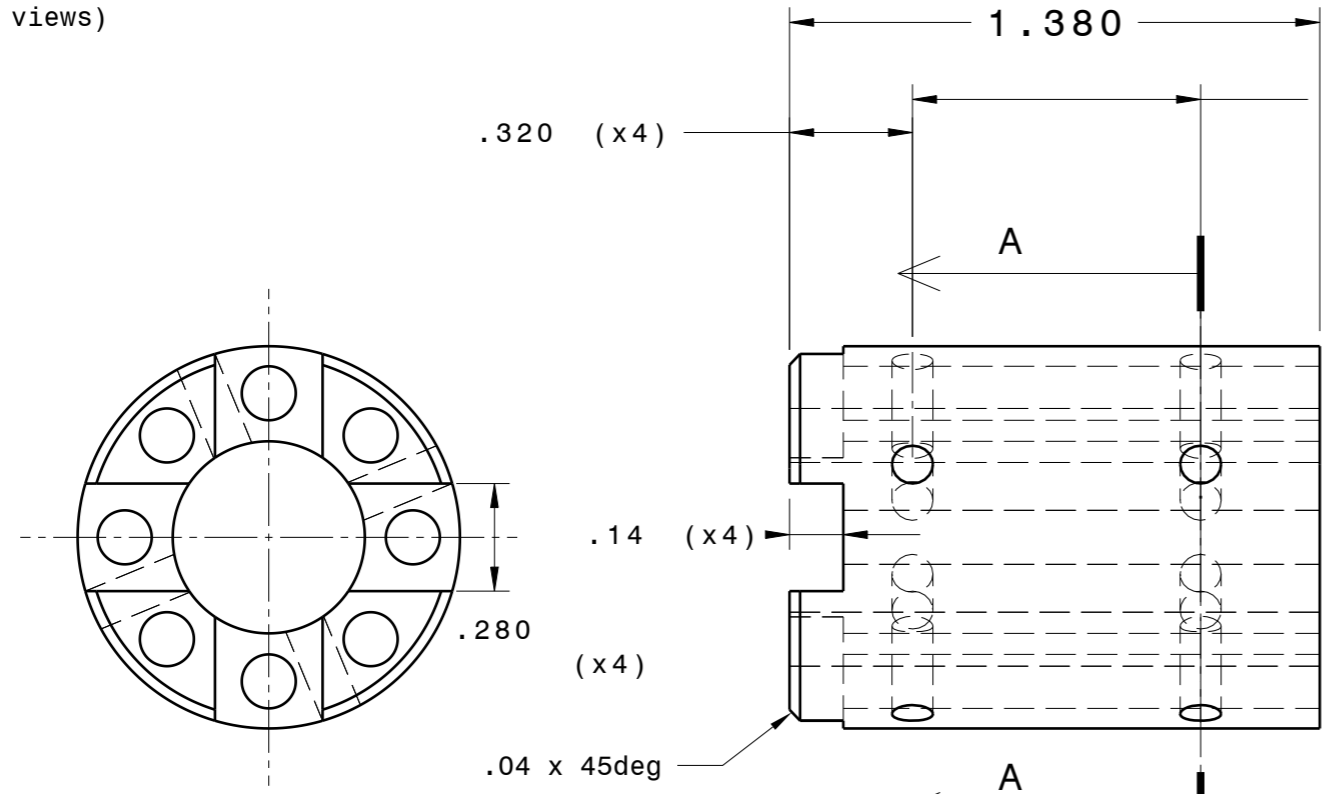

Front view
Scale: 2:1

Right view
Scale: 2:1

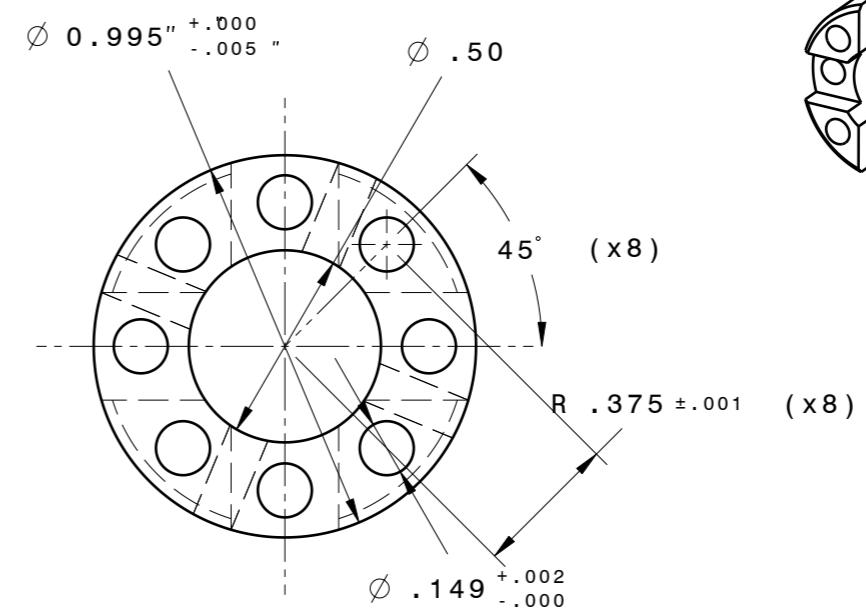

Rear view
Scale: 2:1

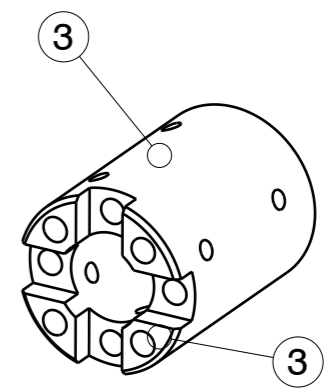

Isometric view
Scale: 1:1

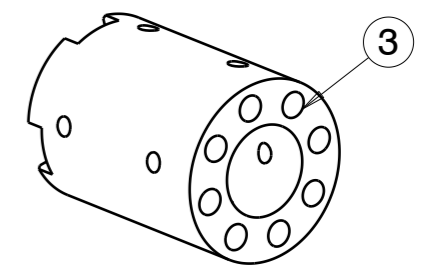

Isometric view
Scale: 1:1

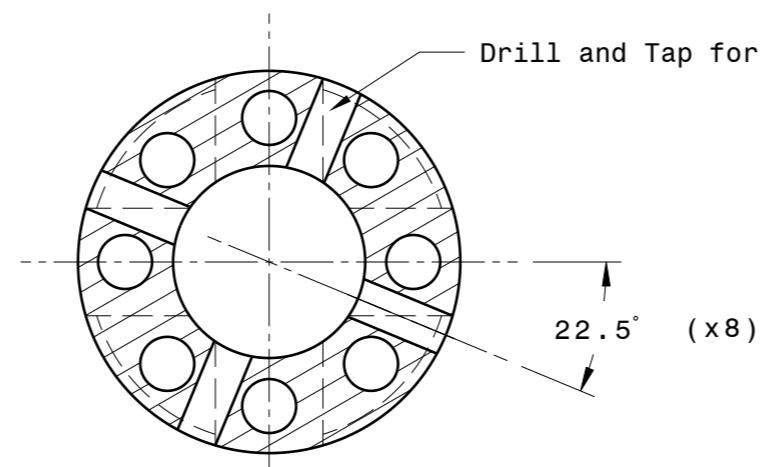

Section view A-A
Scale: 2:1

NOTICE: THIS DRAWING CONTAINS CONFIDENTIAL AND PROPRIETARY DATA ORIGINATED BY CARBON ERECTOR. ALL DESIGN, MANUFACTURING, REPRODUCTION, USE AND SALE RIGHTS ARE EXPRESSLY RESERVED. THE RECIPIENT AGREES BY ACCEPTING THIS DOCUMENT NOT TO SUPPLY OR DISCLOSE ANY INFORMATION REGARDING IT TO ANY UNAUTHORIZED PERSON OR TO INCORPORATE THIS DATA INTO ANY OTHER DESIGN OR USE THEREOF. ALL PATENT RIGHTS ARE EXPRESSLY RESERVED.

DIMENSIONS ARE IN in. UNLESS OTHERWISE SPECIFIED BREAK EDGES/REMOVE BURRS	DRAWN: J. Lewis	DATE: 12/1/14	DWG NAME: 1.0 in Adaptor	
	MATERIAL: Aluminum 6061t6	DATE:		
ANGLES = ± 0.1 deg unless otherwise noted tolerance is ± .010 DO NOT SCALE DRAWING	SCALE: 2 to 1	APPROVED:	SHEET: B	DWG NO: CE10-AD-01
CAGE CODE: N/A				REV: A SHEET: 1 OF 1