

NOTES: UNLESS OTHERWISE SPECIFIED

- 1. ALL SURFACES ARE DERIVED FROM SOLID MODEL.
SOLID MODEL IS THE MASTER AND CONTROLS ALL DIMENSIONS, UNLESS OTHERWISE SPECIFIED.
ENGINEERING WILL SUPPLY ALL DATA UPON REQUEST.
- 2. ALL SURFACES TO BE "AS MACHINED"
- 3. ALL SURFACE SHALL BE FREE FROM SCRATCHES, MARKS, AND ABRASIONS OF ANY KIND.
- 4. Coat part with black oxide

REVISIONS				
ZONE	REV	DESCRIPTION	DATE	APPROVED

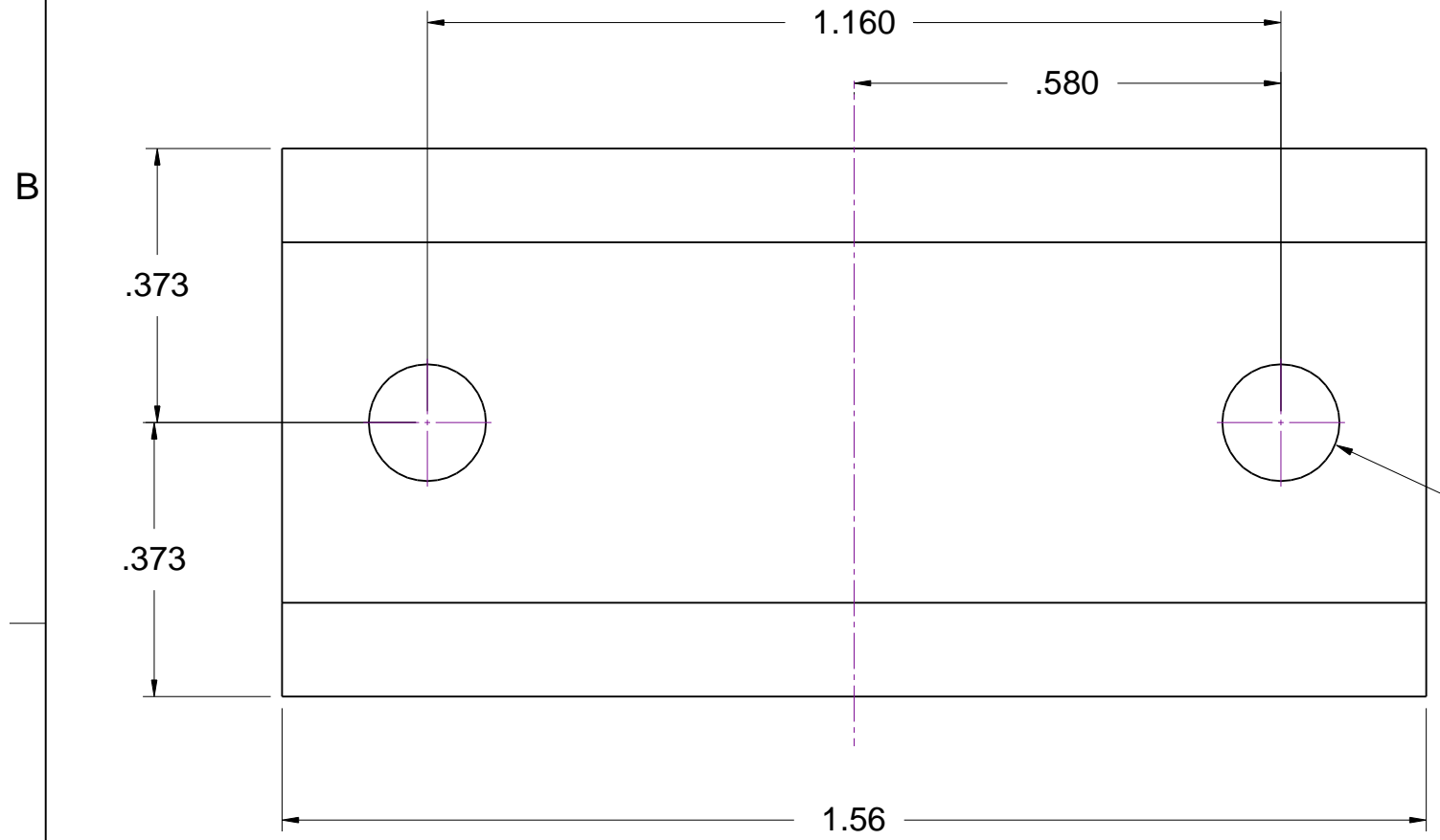

drill and tap for 6-32 td (x2)

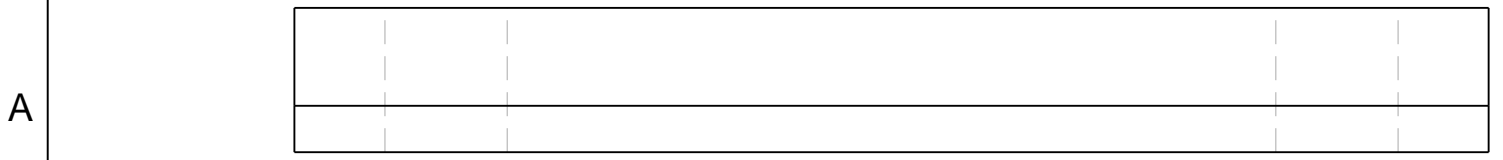
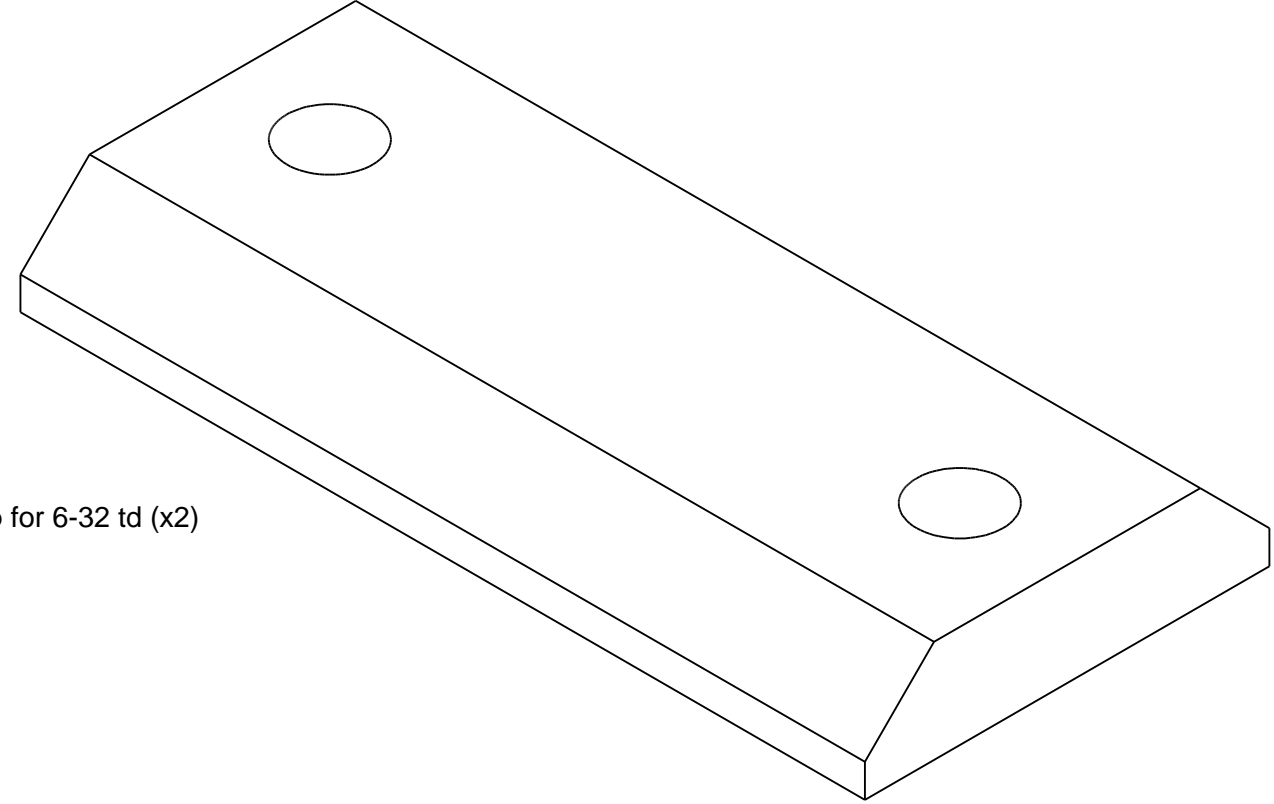

SCALE 4:1

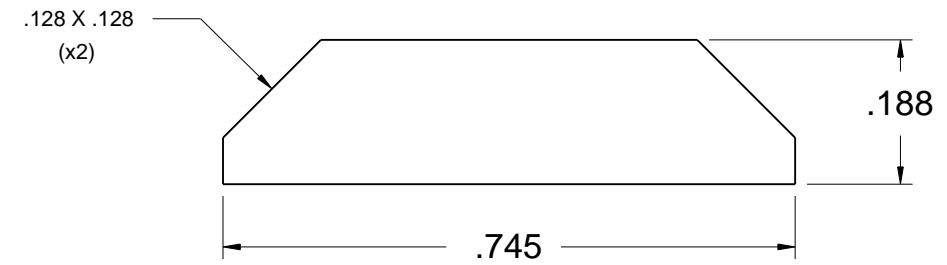

NOTICE: THIS DRAWING CONTAINS CONFIDENTIAL AND PROPRIETARY DATA ORIGINATED BY ROCK WEST COMPOSITES. ALL DESIGN, MANUFACTURING, REPRODUCTION, USE AND SALE RIGHTS ARE EXPRESSLY RESERVED. THE RECIPIENT AGREES, BY ACCEPTING THIS DOCUMENT NOT TO SUPPLY OR DISCLOSE ANY INFORMATION REGARDING IT TO ANY UNAUTHORIZED PERSON OR TO INCORPORATE THIS DATA INTO ANY OTHER DESIGN OR USE THEREOF. ALL PATENT RIGHTS ARE EXPRESSLY RESERVED.

UNLESS OTHERWISE SPECIFIED DIMENSIONS ARE IN INCHES. TOLERANCES ARE: .X ± .050 .XX ± .010 .XXX ± .005 ANGLES: ± 1°	DRAWN J. Lewis	DATE 1/5/16	Part No	
	CHECKED	DATE	CE-80-20 Nut Plate 1.5	
	QA	DATE	SIZE B	CARBON ERECTOR
	APPROVED	DATE	SCALE 4 to 1	SHEET 1 OF 1
DO NOT SCALE DRAWING	MATERIAL 1018 Carbon Steel	SCALE 4 to 1	SHEET 1 OF 1	REV -